



AN/TPQ-37(V)

Reliability and Maintainability Improvement (RMI) Program



AN/TPQ-37(V)8 Radar Set

15 May 2007



AN/TPQ-37(V)

Reliability and Maintainability Improvement (RMI) Program



- **Q-37 Radars are Operating 24/7 in OIF/OEF**
- **Analysis has Shown the Current Transmitter and Cooler Have had Major Operational Impacts on System Availability**
 - Twelve of Fourteen Q-37 Radars Were Reported Non-Mission Capable (NMC) 127 Days - Net Availability 88%
 - Of Those 127 Days, 90 Days Were Due to the Transmitter Faults
 - The Longest Continuous NMC Period was 18 Days due to Transmitter Failure
- **The LRC Database OSMIS Shows Majority of Requisitions are for Transmitter Components**
- **Processor parts are becoming obsolete**
- **Results of a Q-37 Six Sigma Blitz Clearly Identified a Need to Replace the Transmitter and Processor**



AN/TPQ-37(V)

Reliability and Maintainability Improvement (RMI) Program



Transmitter

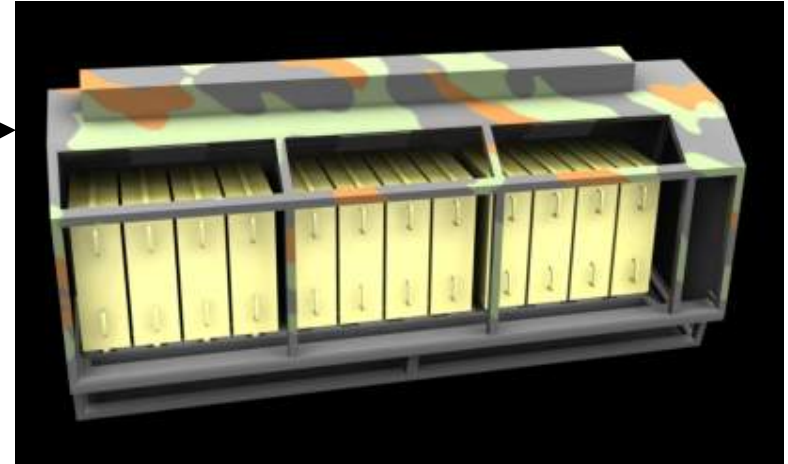

Processor





AN/TPQ-37(V)



Reliability and Maintainability Improvement (RMI) Program

Analysis has Shown the Current Transmitter and Cooler Have had Major Operational Impacts on System Availability

Top Cost Drivers, Availability and Reliability

Old Transmitter

\$2.0M ea

- Traveling Wave Tube
- Low Voltage Drawer
- Grid Deck
- Cooler
- Cathode Body Regulator

105 LRUs

Replacement Cost

\$2.9M ea

New Transmitter
10 LRUs

Old Radar Processor

\$900K ea

- 128 Legacy Radar Processor CCA's

128 LRUs

Replacement Cost

\$200K ea

New Radar Processor
1 LRU

High Reliability = Operational Capability



AN/TPQ-37(V)

Reliability and Maintainability Improvement (RMI) Program



Objectives

- **The Replacement Transmitter Employs a Modular Design Featuring Twelve (12) Power Amplifier Modules (PAMs) Which result in:**
 - Increased Radar System Availability
 - Graceful Transmitter Degradation
 - Sealed Electronics Against Environmental Contaminants
 - Decreased Transmitter Weight and Volume
 - Elimination of Liquid Cooled Components
- **The Common Processor is the Replacement Radar Processor Hardware Developed on the AN/TPQ-36(V)8 Replacement Processor Program to Provide:**
 - A Common AN/TPQ-36/37 Processor
 - A Modern Processor With Current Technology and Open Architecture
 - Growth Path for Future by Increasing Power, Speed and Memory
 - Electronics Meeting Full Mil Temperature Range



AN/TPQ-37(V)

Reliability and Maintainability Improvement (RMI) Program

Common Processor



TPQ-37

- 128 Circuit Cards (86 Unique)
- 20 Cubic Feet
- 3 Kw of Power
- Complex “Wired” Backplane
- Non-Programmable
- No Growth Potential



Upgrade

- 3 VME Cards
- 100% COTS Technology
- Non-Proprietary
- Open Architecture
- Supports Future Software Requirements
- Leverages MPQ-64 Sentinel Software
- New Modern Architecture
- Lighter Weight
- 0.2 KW of Power
- Common With TPQ-36(V)8 Replacement Processor



AN/TPQ-37(V)

Reliability and Maintainability Improvement (RMI) Program Transmitter Replacement



...with this

Traveling Wave Tube (TWT)

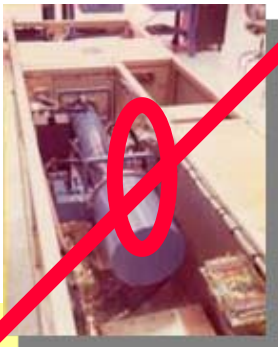

- Fault tolerant
- Increased Availability
- Modular
- Air cooled
- Sealed

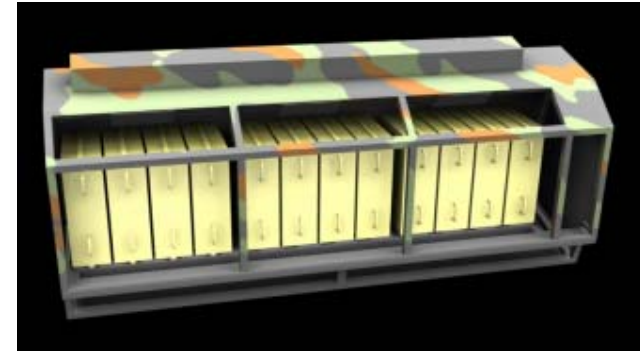

New Transmitter
MTBF = 5,435 Hours

Replace these...

- Single Point Failure
- Parts Obsolescence
- Difficult to Maintain
- Liquid Cooled
 - Vulnerable to Leaks
- Exposed to Ambient Air
 - Airborne Particulate Matter

Cooler

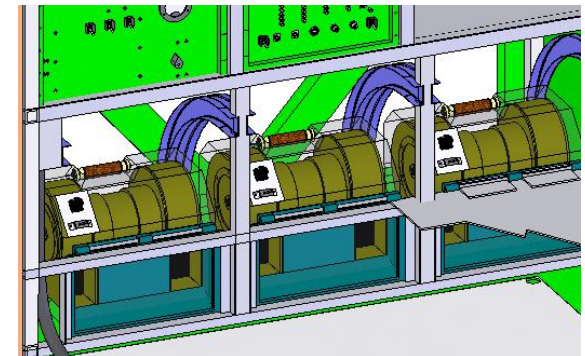

New Air Cooling System
MTBF = 40,000 Hours



AN/TPQ-37(V)

Reliability and Maintainability Improvement (RMI) Program



Cost Analysis & Strategy Assessment (CASA) Life Cycle Cost Model

- Army/AMC Approved Life Cycle Cost Model
- Life Cycle Cost Decision Support Tool
- Acquisition, Operations & Support, Disposal Costs
- Provides Sensitivity Analysis
- Inputs:
 - Hardware Parameters
 - Labor Rates / Locations
 - OPTEMPO

CASA





AN/TPQ-37(V)

Reliability and Maintainability Improvement (RMI) Program



CASA Life Cycle Cost Model

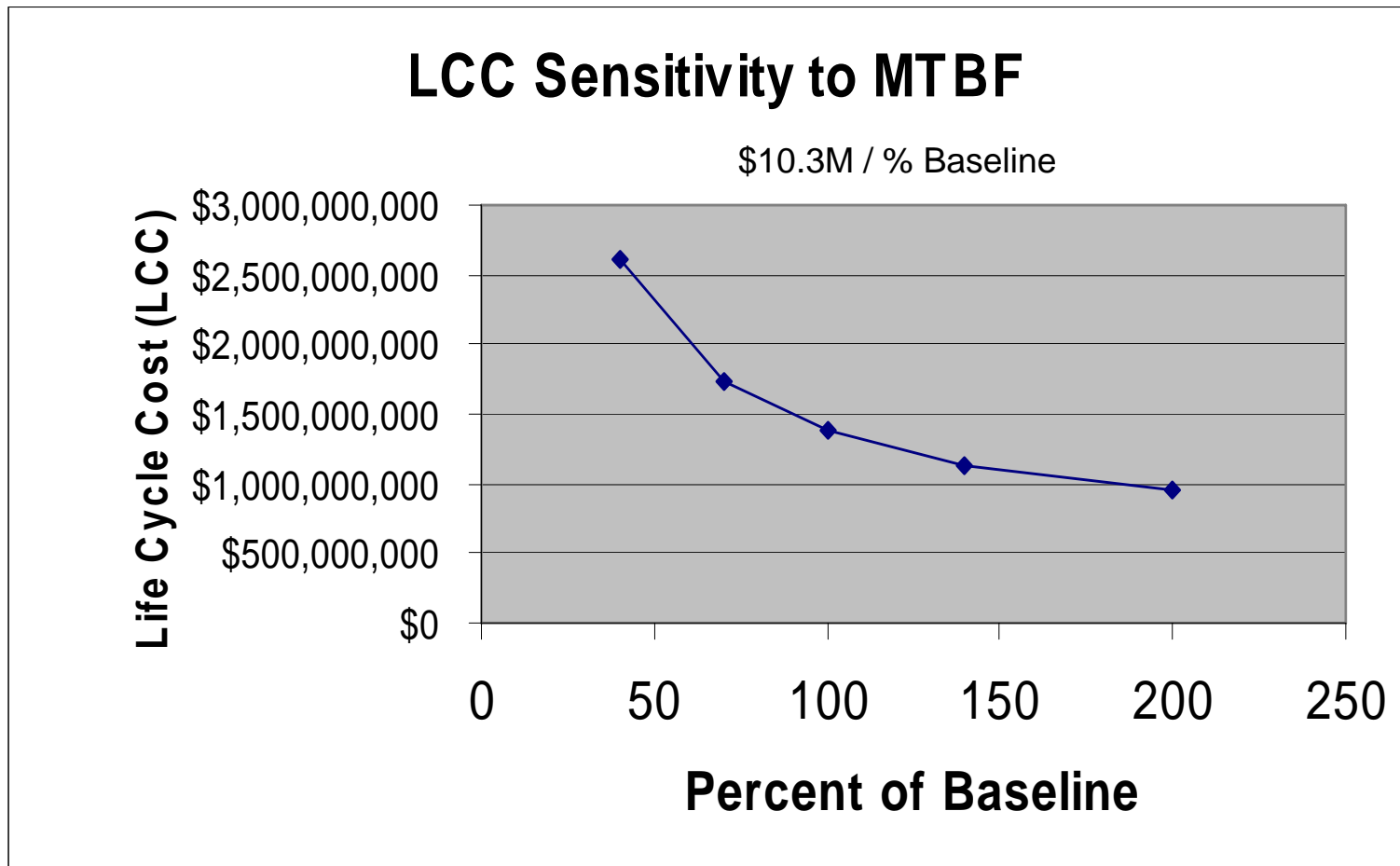



AN/TPQ-37(V)

Reliability and Maintainability Improvement (RMI) Program



CASA Life Cycle Cost Model

LCC Sensitivity to MTTR

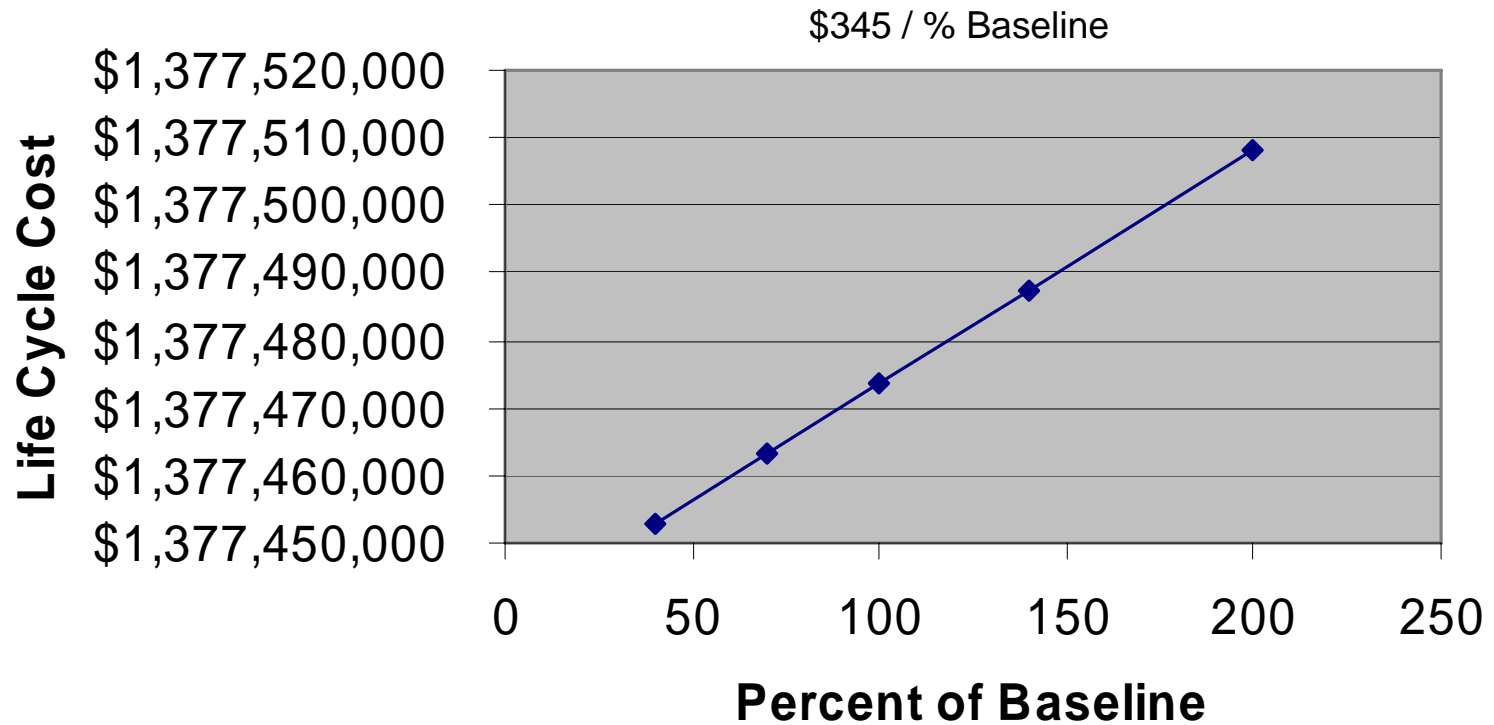



AN/TPQ-37(V)

Reliability and Maintainability Improvement (RMI) Program

CASA Life Cycle Cost Model



LCC Sensitivity to Spares TAT

\$0.6M / % Baseline

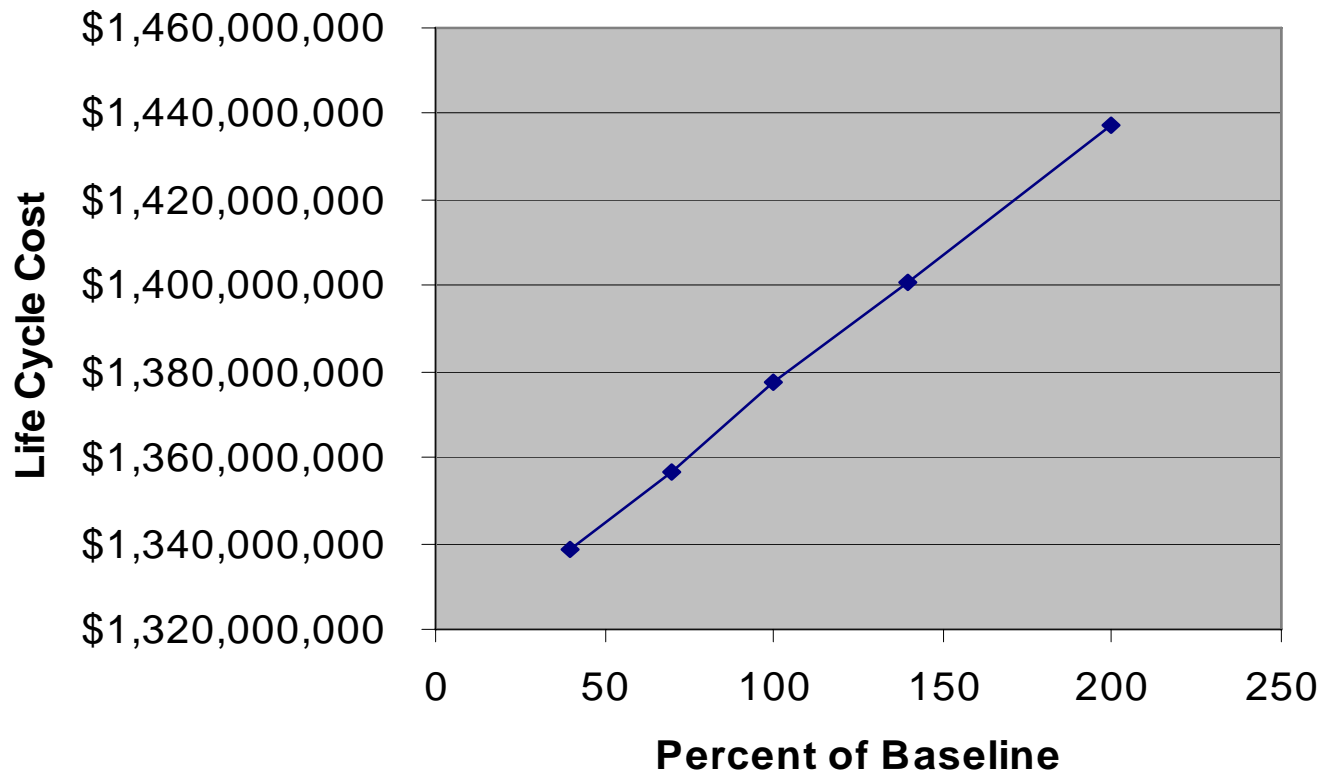



AN/TPQ-37(V)

Reliability and Maintainability Improvement (RMI) Program

CASA Life Cycle Cost Model



LCC Sensitivity to Shipping Cost/Pound

\$20K / % Baseline

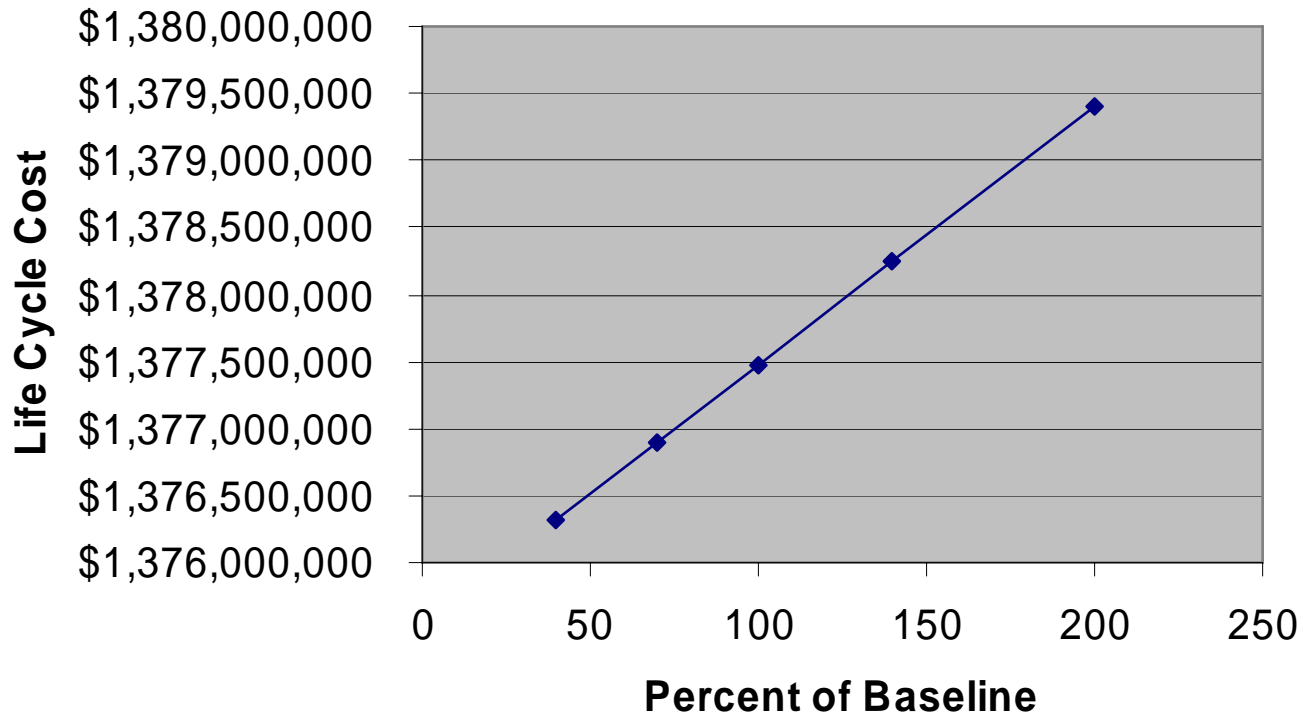



AN/TPQ-37(V)

Reliability and Maintainability Improvement (RMI) Program



RMI Operations & Support (O&S) Cost Savings

- **Total Operations & Support Net Savings for the RMI Program for The Life Cycle from FY08—FY17:**
 - **\$4.44 Billion Dollars**
 - Is \$192 Million Dollars (Average) In Savings Per Year During The ‘Phase-In’ Timeframe (FY08—F11)
 - Is \$611 Million Dollars In Savings Per Year During The ‘Steady State’ Timeframe (FY12— FY17)
 - Has an ROI of 20-to-1
- **O&S Costs Include the Spares Costs**

RMI Program Will Provides \$4.4 Billion Dollars O&S Savings Over Ten Years



AN/TPQ-37(V)

Reliability and Maintainability Improvement (RMI) Program



Phase I

- **Program Name:** AN/TPQ-37 Reliability and Maintainability Improvement (RMI) Program
- **Program Description:** Prove Out Transmitter and Processor for Contractor Technical Refreshment CTR for the AN/TPQ-37
- **Program Phase:** One (1) System Tested with Spares
- **Program Duration** 16 Months



AN/TPQ-37(V)

Reliability and Maintainability Improvement (RMI) Program



Current Phase I Status

- **Post Award Conference/Advance Design Review Held Nov 06**
 - Included Review of Full Scale Mock-ups
- **Successful Preliminary Design Review (PDR) Held 23 Jan 07**
 - Included Review of Hardware/Software Design Specs
- **Successful Critical Design Review (CDR) Held 1 May 07**
 - 85% Hardware Complete
- **Live Fire Testing (LFT) Nov 07**
- **Initiated Work at Key Suppliers**
 - Thales Raytheon Systems: Common Processor/Software
 - Technovative: Transmitter/Cooler Design
 - TMD: PAM Production/Design
 - Teledyne: TWT Reconditioning
 - Donaldson: Filterization System



AN/TPQ-37(V)

Reliability and Maintainability Improvement (RMI) Program



Common Processor

- Power Supply
- Control Processor
- Signal Processor
- Clock Regenerator

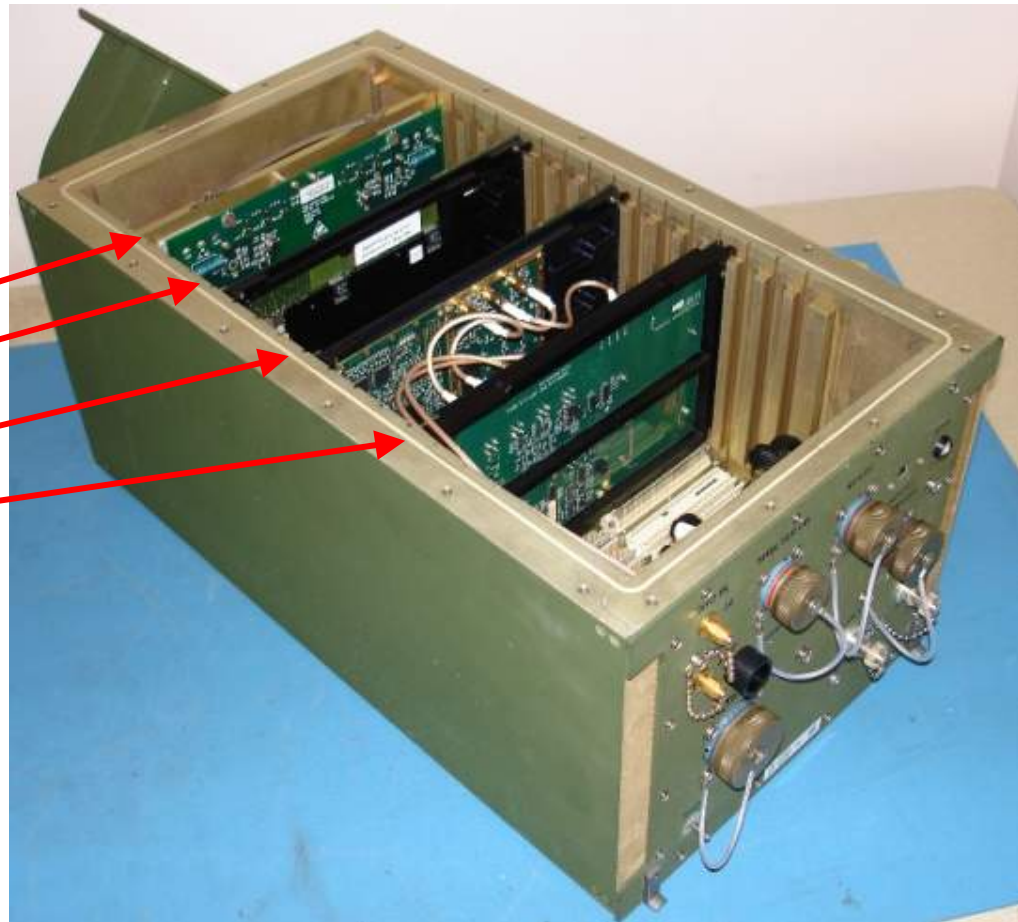



AN/TPQ-37(V)

Reliability and Maintainability Improvement (RMI) Program
Power Amplifier Module, PAM





AN/TPQ-37(V)

Reliability and Maintainability Improvement (RMI) Program

12 Slide in PAMs in a Row

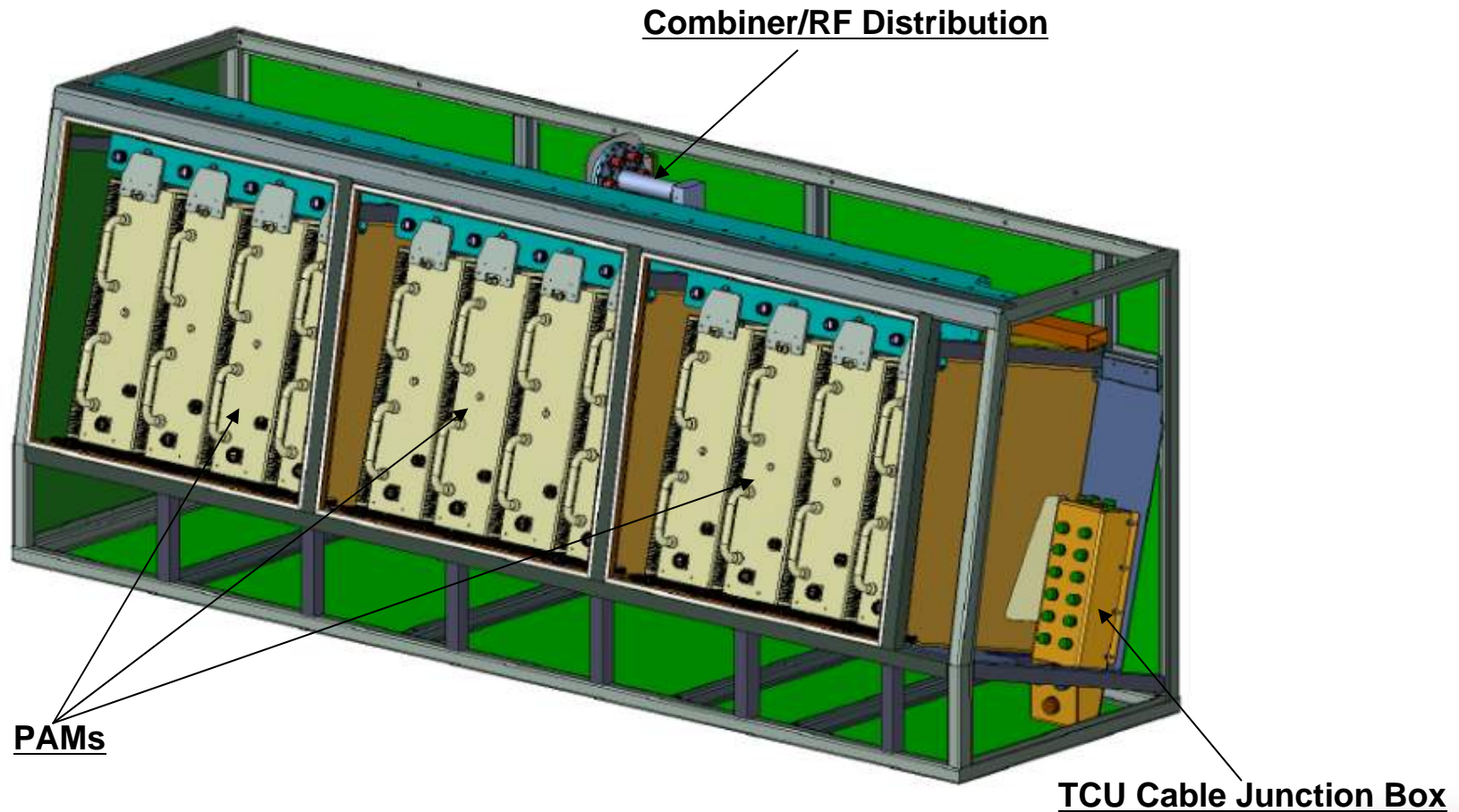



AN/TPQ-37(V)

Reliability and Maintainability Improvement (RMI) Program

12 PAMs in a Row





AN/TPQ-37(V)

Reliability and Maintainability Improvement (RMI) Program



Antenna Group Tub

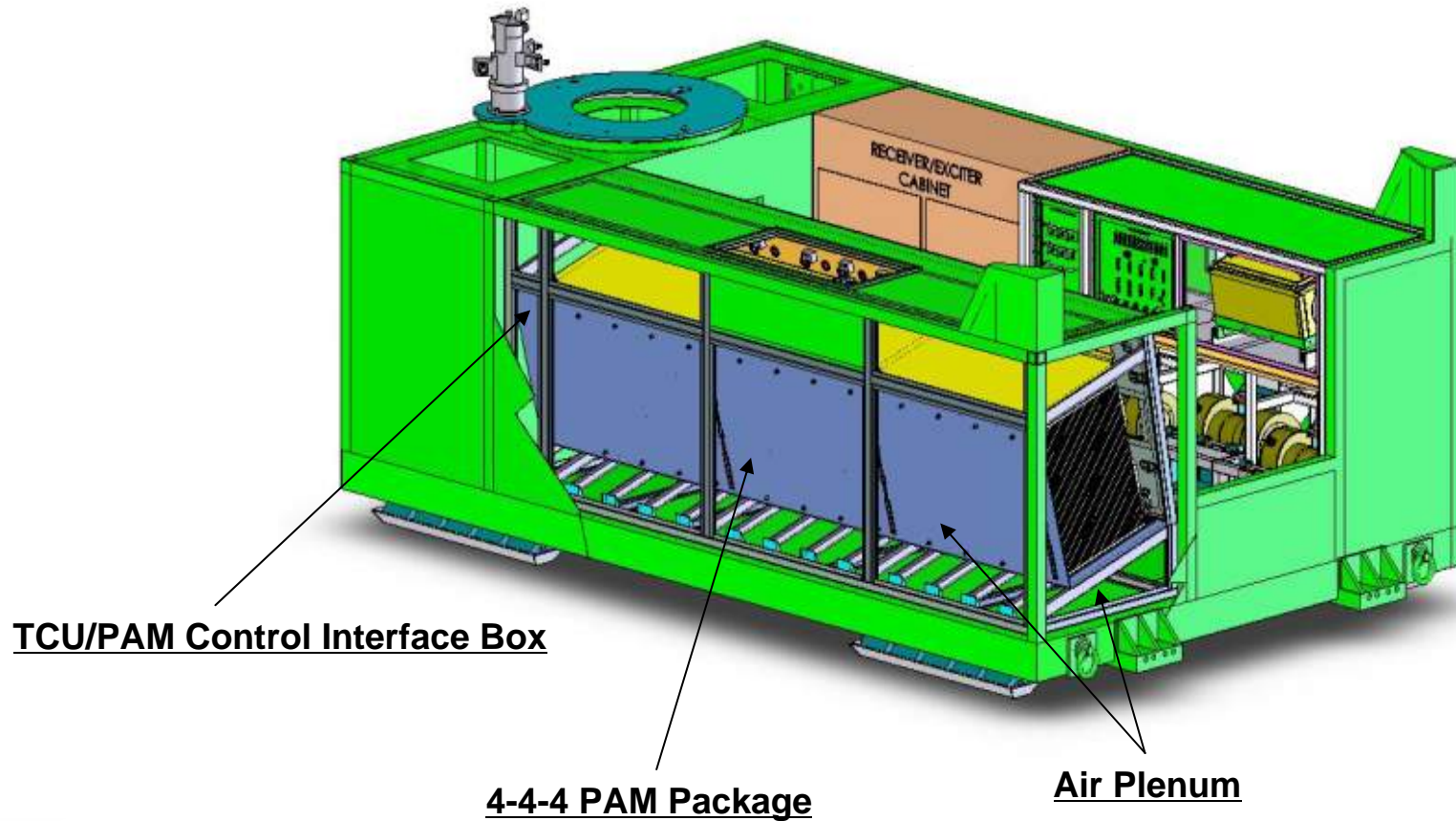



AN/TPQ-37(V)

Reliability and Maintainability Improvement (RMI) Program

Antenna Group Tub





AN/TPQ-37(V)

Reliability and Maintainability Improvement (RMI) Program

Antenna Group Tub

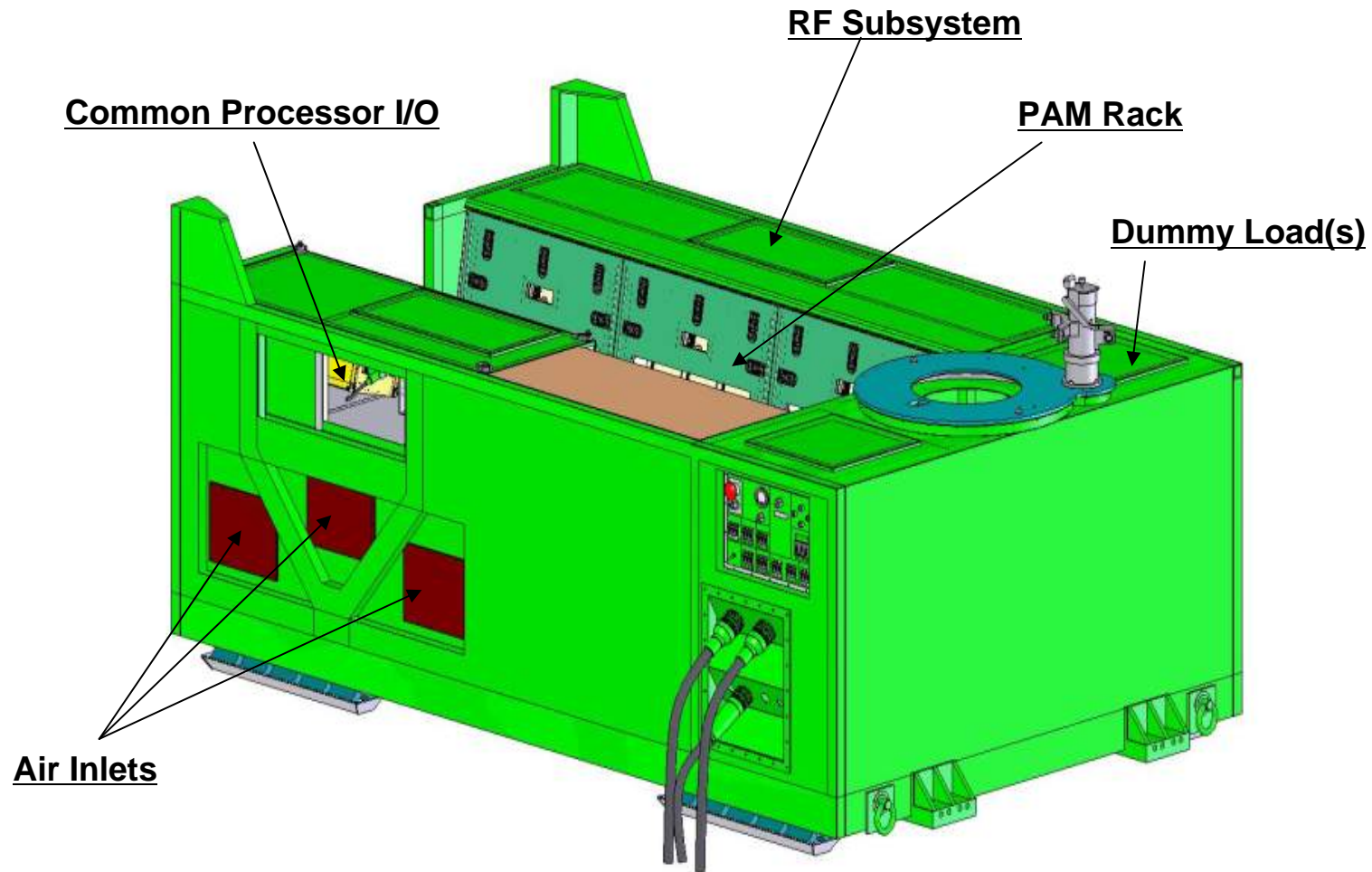



AN/TPQ-37(V)

Reliability and Maintainability Improvement (RMI) Program

Antenna Group Tub





AN/TPQ-37(V)

Reliability and Maintainability Improvement (RMI) Program

Blower LRU Removal Design

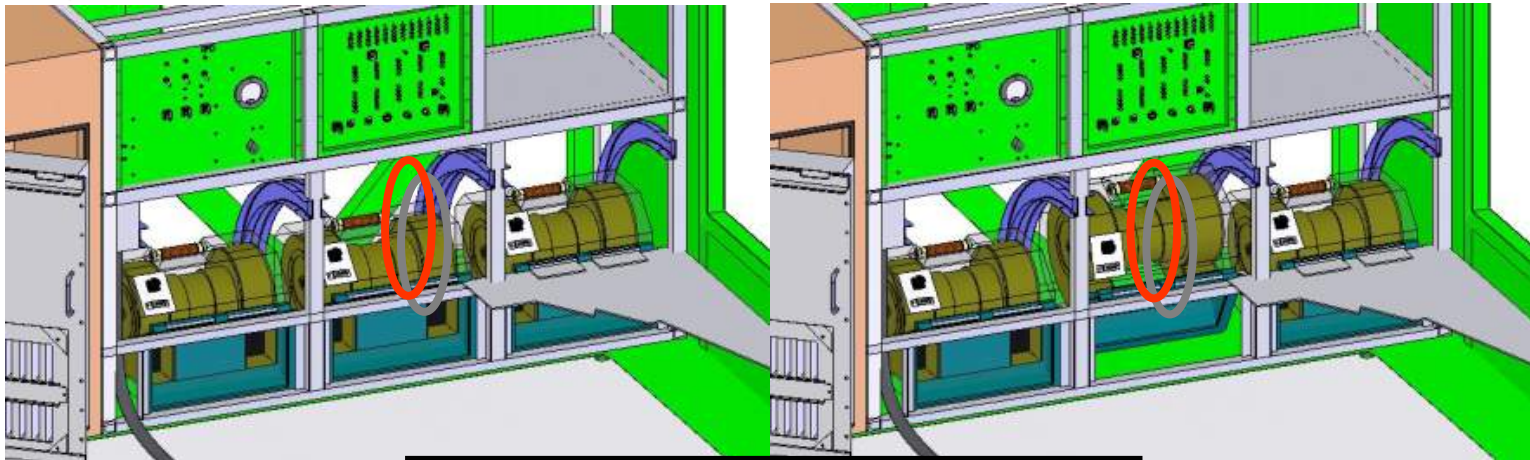

**Blowers Rotate Toward Front
for Easy Removal**

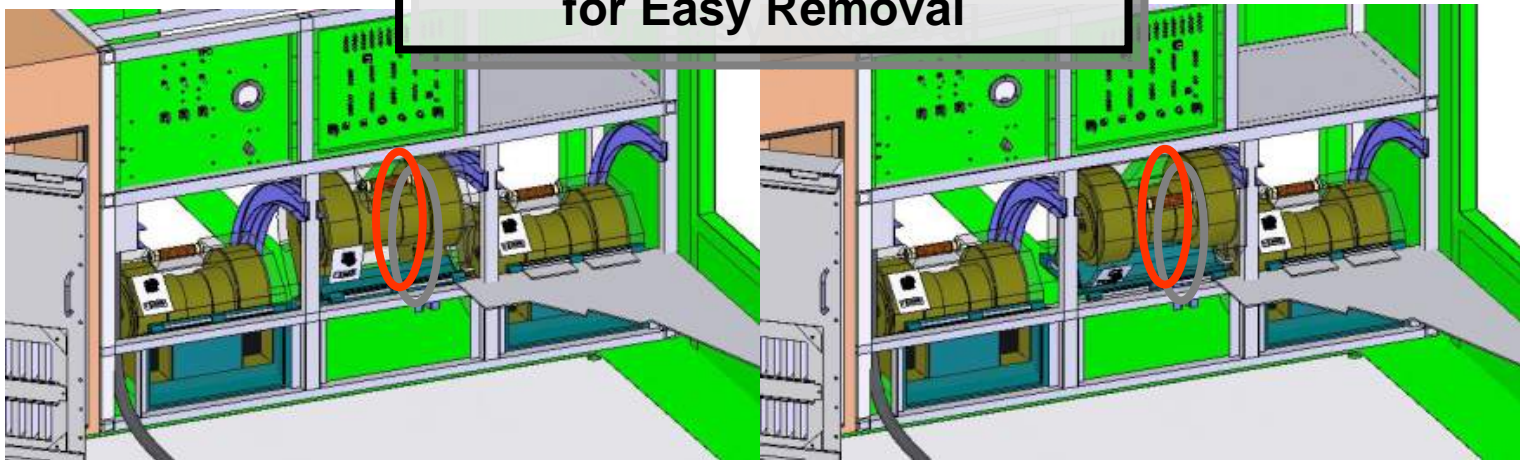



AN/TPQ-37(V)



Reliability and Maintainability Improvement (RMI) Program

Water Cooling Replaced with Air Cooling

Air Mover Uses Three Duplex Blowers to Deliver Cooling Air to Power Amplifier Modules.

Number of Blowers Operating is Determined by Power Amplifier Module Temperature

- **Controlled by Transmitter Control Unit**
- **Reduces Power/Fuel Consumption**
- **Extends Filter Cleaning Interval and Blower Life**

Blower Supportability Design Elements

- **Easy to handle enclosure**
- **Single handle pull**
- **Quick release**

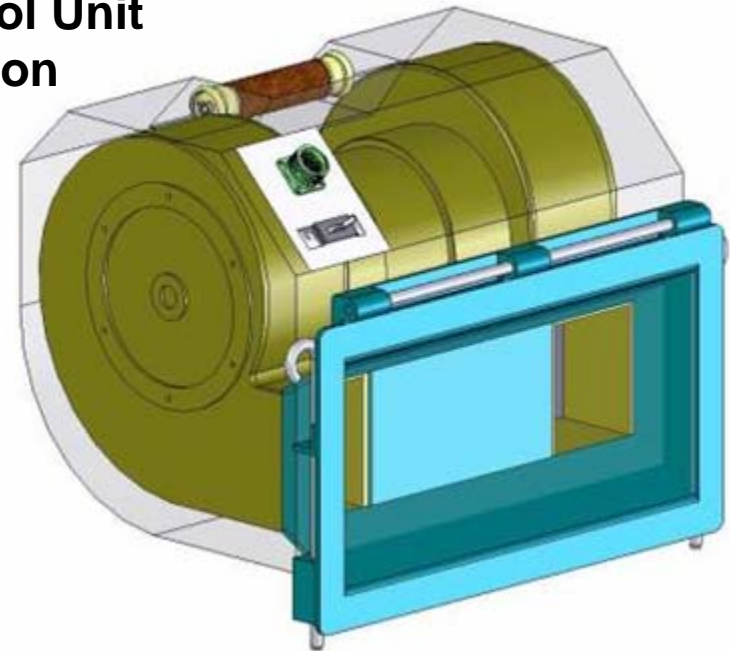



AN/TPQ-37(V)

Reliability and Maintainability Improvement (RMI) Program

Ametek Rotron Blower Assembly





AN/TPQ-37(V)

Reliability and Maintainability Improvement (RMI) Program



Maintenance Free Air Filtration System

- **Donaldson Defense Systems has delivered the maintenance free air filtration system for the RMI program. Donaldson's technology offers:**
 - Increased filtration efficiency when compared to conventional woven or foam materials
 - Filtration down to sub-micron particle size (efficiency is impacted by particle size)
 - No maintenance once installed
- **RMI configuration packages with complete blower/scavenge fan/filter correlation. 3 independently TCU command operated airflow circuits exist.**



AN/TPQ-37(V)

Reliability and Maintainability Improvement (RMI) Program

Maintenance Free Air Filtration System



- Maintenance free
- Long life (MTBF to be determined)
- Stable efficiency
- No replacement parts
- Easy to replace element (5 min. MTTR), 4 retained quarter turn fasteners
- Bottom exit scavenge tube
- Passive, low cost





AN/TPQ-37(V)

Reliability and Maintainability Improvement (RMI) Program



Maintenance Free Air Filtration System

How a Strata Tube Works!

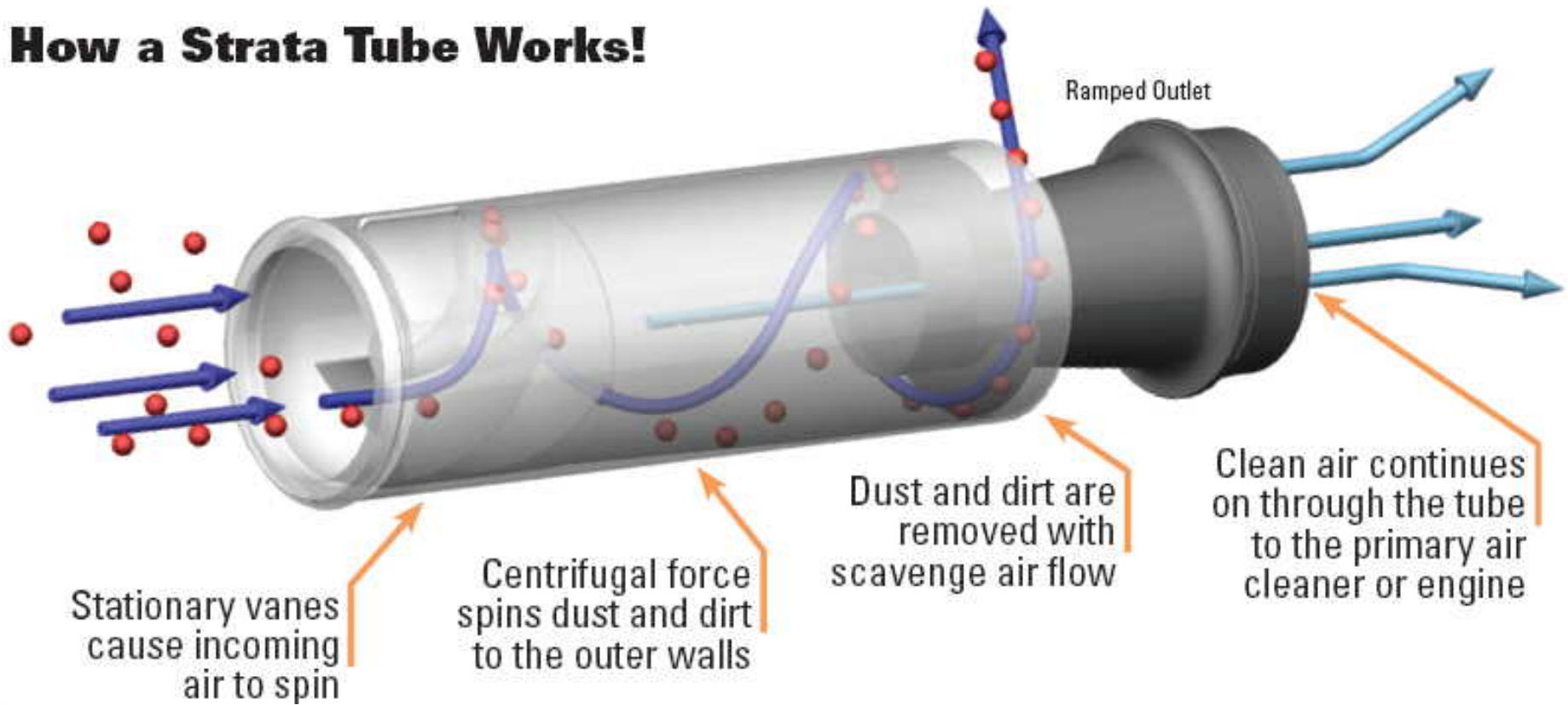



AN/TPQ-37(V)

Reliability and Maintainability Improvement (RMI) Program



Transmitter Control Unit (TCU)

- **Transmitter Control Unit (TCU) Designed to Improve Fault location.**
- **Hardware based on Similar Battlefield Radars**
 - LED indications of PAM Status
 - Detailed PAM fault information can be selected (minimizes LEDs)
 - Interface to external computer (Ethernet port)
 - Additional Ethernet port available for future radar processor interface.
- **Improvements include**
 - Test Switch /External Trigger
 - RF Power Indicator
 - Communication Indicator



AN/TPQ-37(V)

Reliability and Maintainability Improvement (RMI) Program



TCU Front Panel - Designed to Improve Fault location

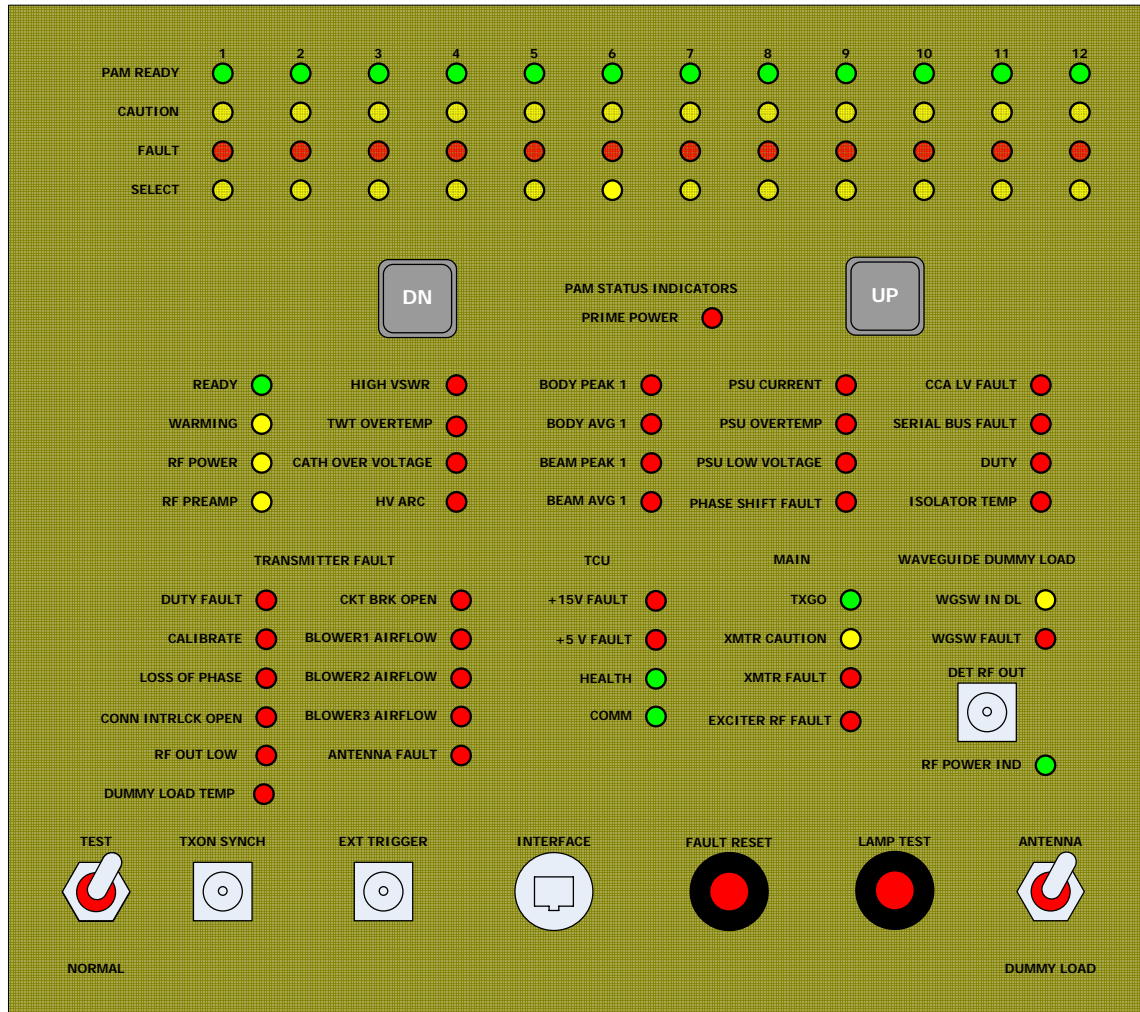



AN/TPQ-37(V)

Reliability and Maintainability Improvement (RMI) Program



Improved TCU Layout

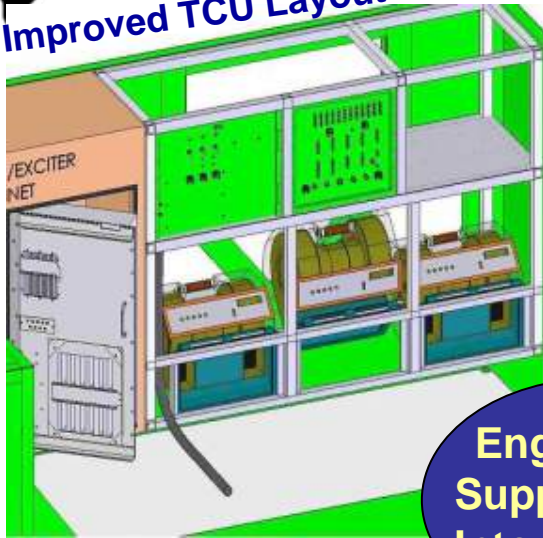

Common Radar Processor

- Power Supply
- Control Processor
- Signal Processor
- Clock Regenerator

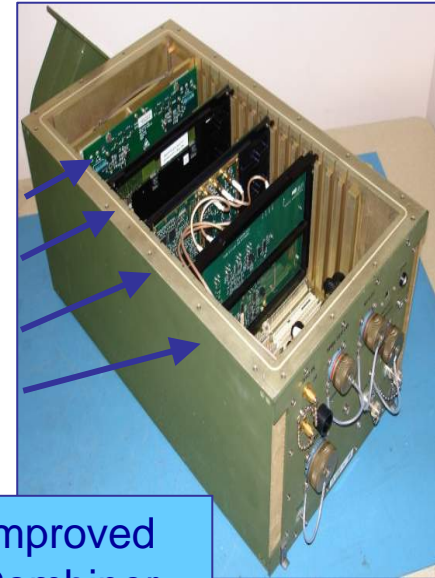

Engineering Supportability Into the Radar

Improved Combiner Design

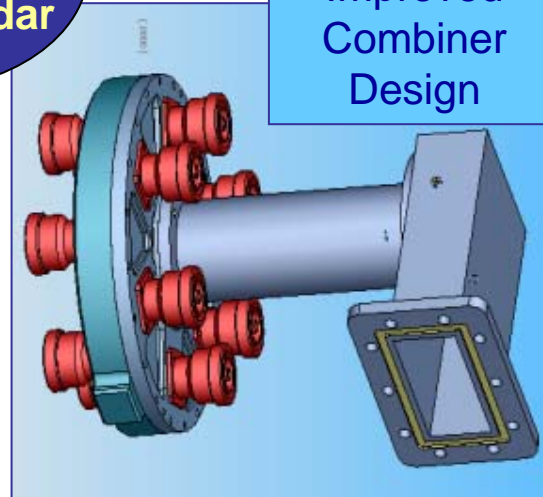

37 RMI Transmitter Redesigned



AN/TPQ-37(V)

Reliability and Maintainability Improvement (RMI) Program



Conclusion

- PM Radars/ LCMC Meet Army Modularity Requirement
- Sustainment of AN/TPQ-37(V)8 Radar System for 10 years
- Reliability Improvement Ratio 10:1
- Return on Investment Ratio 20:1

Sustaining the Force



AN/TPQ-37(V)

Reliability and Maintainability Improvement (RMI) Program



CREATIVITY

Sometimes brilliance shines though from desperation; other times it shows just how desperate we have become.

DIY.DESPAIR.COM